



## Features and benefits:

- Large 25mm or 1" LCD Display
- High Accuracy
- Selectable Units te, lbs, kN & kg
- High Resolution
- Compact Size
- Tare
- Preset Tare
- Lightweight
- Overload Counter
- 90dB Audible Set Point Alarm
- RS-485 Serial Output
- Corrosion-Resistant Finish

Optional connection to Straightpoint's Handheld plus - **SP Crosby** Part Nos. **HHP 2789030**

**This small and compact mini crane weigher scale will suit most lifting applications and is available in capacities from 100kg to 5t.**

**Worldwide, it is Straightpoint's most popular product and has been manufactured since 1987. The Miniweigher plus crane scale offers robust construction, high accuracy, compact size and extreme portability.**

Utilised by utility companies on every continent, the Miniweigher plus crane scale is quite often mounted between a winch and a tripod. This mounting point allows for load monitoring to be integrated within the lift, ensuring safety levels during the lowering and raising of equipment and/or personnel are optimised. It has proven itself to be an indispensable tool for underground sewer, water, gas and utility vault access.

The Miniweigher plus features full function push button controls for tare, choice of units (lbs, kg, kN and tonnes), peak hold, preset tare, audible set-point alarm and an overload counter.

Straightpoint's advanced microprocessor based electronics provide the Miniweigher plus with high speed read rates, extreme resistance to industrial level noise and unprecedented stability. This high stability allows 5,000+ divisions and the highest standard resolution of any compact digital crane scale on the market today. The unit also features a RS-485 serial output providing added functionality and versatility.

In all, the lightweight design, corrosion-resistant finish, advanced electronics and full feature display have made the Miniweigher plus crane scale the only choice when looking for a compact, safe and accurate, crane scale.

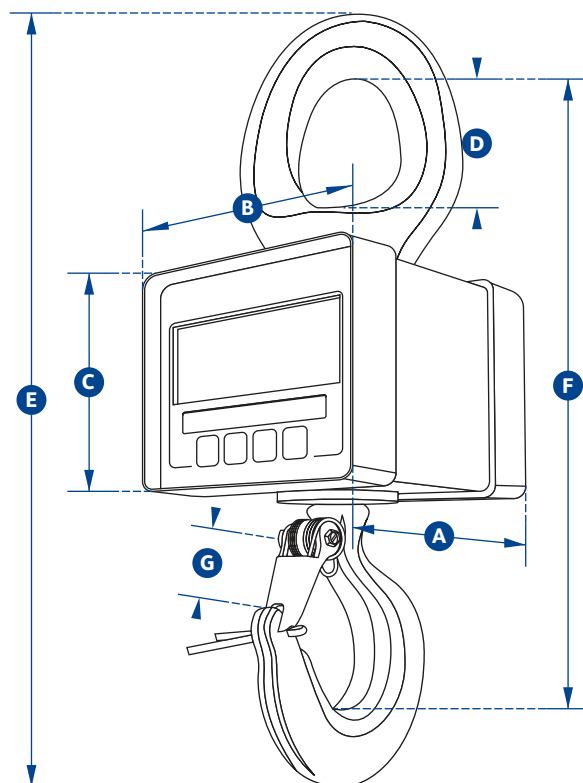

Part Numbers	MWP100KG	MWP250KG	MWP500KG	MWP1T	MWP2T	MWP5T
SP	2789055	2789057	2789059	2789056	2789058	2789060
Capacity	100kg 220lb	250kg 550lb	500kg 1100lb	1000kg 2200lb	2t 4400lb	5t 11000lb
Resolution	0.05kg 0.1lb	0.1kg 0.2lb	0.2kg 0.5lb	0.5kg 1lb	0.001t 2lb	0.001t 2lb
Units	t, kg, kN and lb lb, t, kg and kN					
Weight	1.5kg 3.3lb	1.5kg 3.3lb	1.5kg 3.3lb	1.5kg 3.3lb	3.1kg 6.8lb	8.7kg 19.2lb
Safety Factor	10:1	5:1	5:1	5:1	5:1	5:1
Battery Type	9v PP3					
Battery Life	80 hours continuous					
Display Type	6 digit 25mm LCD or 6 digit 1" LCD					
Operating Temp	-10°C to +50°C or 14°F to 122°F					
Accuracy	±0.1% of full scale					
Protection	IP65 or NEMA4X					
Dimension A	81 3.19"	81 3.19"	81 3.19"	81 3.19"	117 4.61"	136 5.35"
Dimension B	112 4.41"	112 4.41"	112 4.41"	112 4.41"	112 4.41"	112 4.41"
Dimension C	81 3.19"	81 3.19"	81 3.19"	81 3.19"	92 3.62"	92 3.62"
Dimension D	33 1.30"	33 1.30"	33 1.30"	33 1.30"	43 1.69"	62 2.44"
Dimension E	222 8.74"	222 8.74"	222 8.74"	222 8.74"	283 11.14"	349 13.74"
Dimension F	183 7.20"	183 7.20"	183 7.20"	183 7.20"	238 9.37"	286 11.26"
Dimension G	22 0.87"	22 0.87"	22 0.87"	22 0.87"	28 1.10"	42 1.65"