

## Eyebolts to DIN 580

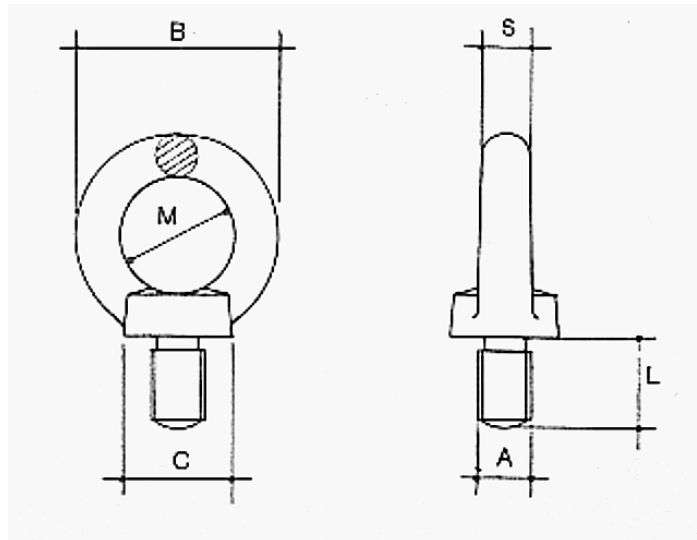

### Metric Coarse Thread

SWL (KGs)	A (mm)	B (mm)	C (mm)	L (mm)	M (mm)	S (mm)	Weight (KGs)
70	6	36	20	13	20	8	0.06 *
140	8	36	20	13	20	8	0.06
230	10	45	25	17	25	10	0.11
340	12	54	30	20.5	30	12	0.18
490	14	63	35	27	35	14	0.28 *
700	16	63	35	27	35	14	0.28
900	18	72	40	30	40	16	0.41 *
1200	20	72	40	30	40	16	0.42
1500	22	81	45	35	45	18	0.67 *
1800	24	90	50	36	50	20	0.84
2500	27	90	50	36	50	20	1.22 *
3600	30	108	65	45	60	24	1.66
4300	33	108	65	45	60	24	2.16 *
5100	36	126	75	54	70	28	2.65
6100	39	126	75	54	70	28	3.34 *
7000	42	144	85	63	80	32	4.03
8000	45	144	85	63	80	32	5.21 *
8600	48	166	100	68	90	38	6.32
11500	56	184	110	78	100	42	8.80
16000	64	206	120	90	110	48	12.40

Sizes marked \* are additional and proportional to the specification

Direction of pull	Maximum Loadings by piece lifted in Kgs												
	1 bolt	140	230	340	700	1200	1800	3600	5100	7000	8600	11500	16000
0°	1 bolt	140	230	340	700	1200	1800	3600	5100	7000	8600	11500	16000
45°	2 bolts	95	170	240	500	830	1270	2600	3700	5000	6100	8300	11000

- **Other thread sizes are also available.**
- **Also available in Stainless Steel – see page 80.**