

Collared Eyebolts to BS 4278 1984

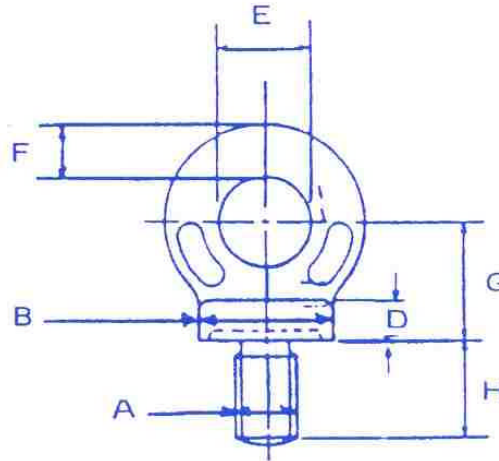

Metric Coarse Thread

SWL (KGs)	A (mm)	B (mm)	D (mm)	E (mm)	F (mm)	G (mm)	H (mm)
*100	6	22	7	15	9	20	18
*150	8	22	7	15	9	20	18
*250	10	22	7	15	9	20	18
400	12	22	7	15	9	20	18
*500	14	29	10	20	12	26	23
800	16	29	10	20	12	26	23
*1000	18	36	12	24	14	32	28
1600	20	40	14	27	16	36	32
*1600	22	45	14	30	17	40	35
2500	24	52	17	35	21	46	40
*2500	27	58	20	39	23	52	46
4000	30	65	22	44	26	58	51
*4000	33	72	24	48	29	64	56
6300	36	81	27	54	32	72	63
*6300	39	86	29	57	33	76	67
8000	42	101	34	68	40	90	79
*8000	45	101	34	68	40	90	79
*10000	48	101	34	68	40	90	79
12500	52	115	38	76	46	102	89
16000	56	128	43	86	51	114	100
20000	64	144	48	96	58	128	112

Sizes marked * are additional and proportional to the specification.

Long shank Collared eyebolts are also available.

Other thread sizes are also available.