

WH-BC Fixed Jaw Super Clamp

Manufactured in accordance with BS EN13155: 2003 + A2: 2009 - Cranes - Safety - Non Fixed Load Lifting Attachments.

The WH-BC fixed jaw super clamp is fitted with a 'gussett' in both jaws of the beam clamp maximising contact between the beam and beam clamp increasing the grip of the beam clamp. A shackle is fitted to the bottom of the beam clamp allowing an easy connection of the hoist to be attached.

This fixed jaw super clamp can be used to an angle of 45° to the vertical. When the angle is moved away from the vertical the working load limit of the beam clamp needs to be reduced. Please refer to the table opposite - reduction in working load limits when side loads are applied.

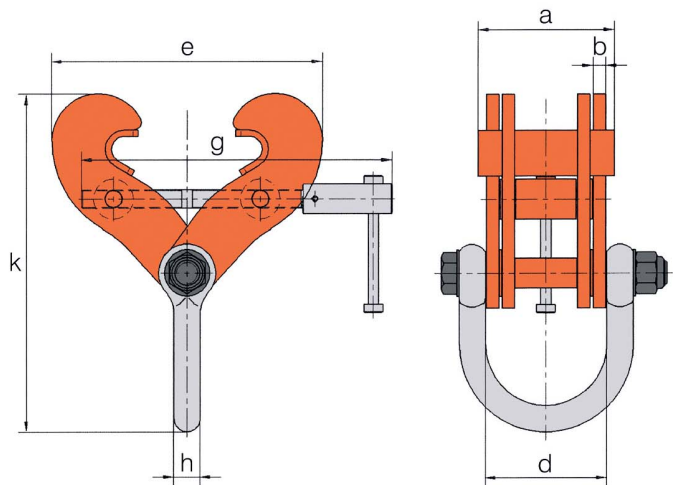

Specifications

Part Code	Model No.	WLL tonnes	Beam Range mm	a mm	b mm	d mm	e max	e min	g mm	k max	k min	h mm	Mass kg
027.200	WH-BC2	2.0	76-190	130	3	90	254	133	275	263	223	20	4.0
027.300	WH-BC3	3.0	76-190	130	12	102	275	166	275	289	251	20	8.0
027.300.E	WH-BC3A	3.0	127-350	130	12	102	438	228	560	375	294	20	11.5
027.400	WH-BC4	4.0	150-254	130	10	112	371	185	410	369	308	25	11.0
027.500	WH-BC5	5.0	76-190	130	12	116	306	191	295	338	300	25	10.0
027.500.E	WH-BC5W	5.0	150-305	130	12	116	422	264	410	413	360	25	15.0
027.600	WH-BC6	6.0	203-457	140	12	116	608	267	560	511	402	25	18.8
027/1000	WH-BC10	10.0	203-457	140	20	118	608	267	560	530	421	32	28.0
027/1500	WH-BC15	15.0	203-457	170	20	116.5	648	400	660	684	608	40	49.5
027/1500.E	WH-BC15W	15.0	406-610	170	20	116.5	800	600	810	812	706	40	58.5

Anglia Handling Services Ltd.

Montgomery Way
Stratton Business Park
Biggleswade
Bedfordshire
SG18 8QB

Tel: +44 (0) 1767 312125
Fax: +44 (0) 1767 601375
sales@angliahandling.co.uk
www.angliahandling.co.uk

Biggleswade

Side loaded across beam only, as illustrated

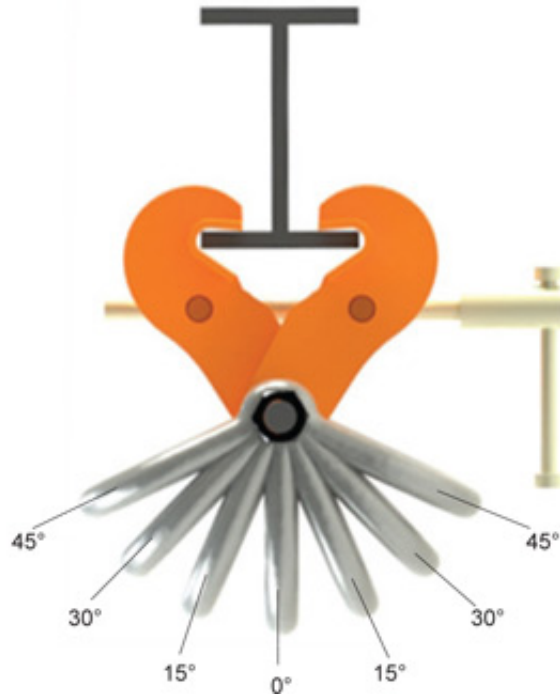

Reduction in Working Load Limits when side loads are applied

Angle from Vertical	0°	0° to 15°	15° to 30°	30° to 45°
Reduction Factor	Nil	17%	34%	50%
Models	WLL	WLL	WLL	WLL
027.200	2 tonne	N/A	N/A	N/A
027.300,027.300.E	3 tonne	2.5 tonne	2 tonne	1.5 tonne
027.400	4 tonne	3.3 tonne	2.6 tonne	2 tonne
027.500, 027.500.E	5 tonne	4.1 tonne	3.3 tonne	2.5 tonne
027.600	6 tonne	5 tonne	4 tonne	3 tonne
027/1000	10 tonne	8.3 tonne	6.5 tonne	5 tonne
027/1500, 027/1500E	15 tonne	12.4 tonne	10 tonne	7.5 tonne

The above working load limits and derations have been established specifically for most William Hackett clamps and only apply in overhead beam attachment i.e: DO NOT apply if clamps are to be used for lifting beams.

The tables apply to our clamps only (selected models) and we strongly advise that stress calculations should be carried out (by the user's engineering department) for all support steelwork.

WARNING: All clamps must be correctly applied to the beam by a competent person and fully hand tightened. If in doubt, contact the manufacturer for their recommendations.

NOTE: Clamp model WH-BC (027.200) is not suitable for any side loading as it is of lightweight design.

Although we are confident that our beam clamps could operate at 90° without any reduction in efficiency, William Hackett do not recommend this type of use in application, there will be a significant overturning moment generated on the beam flange and this could result in the actual supporting structure being permanently deformed and or damaged. If clamps are used in any other way than that indicated above, William Hackett will not accept any liability and would strongly recommend that this unsafe practice is not adopted.