

Beam clamp YC



Beam clamp model YC

Capacities 1.000 - 10.000 kg

Provides a quick and versatile rigging point for hoisting equipment, pulley blocks or loads.

Flexible application due to wide adjustment range.

The central threaded spindle allows easy attachment and a safe and secure grip.

The spindle can be secured against loosening.

Optional: can be supplied with shackle.

Flattened, reinforced version for use on beams with reduced web height available on request

Model	Capacity kg	Flange width mm	Weight kg
YC 1	1000	75 - 230	3,8
YC 2	2000	75 - 230	4,6
YC 3	3000	80 - 320	9,2
YC 5	5000	90 - 320	11,0
YC 10	10000	90 - 320	17,2

Capacity kg	A _{min.} mm	A _{max.} mm	A ₁ mm	A ₂ mm	B ₁ mm	B ₂ mm	b ₁ mm	b ₂ mm	C mm	D mm	E mm	F ₁ mm	F ₂ mm	G ₁ mm	G ₂ mm	H mm	J ₁ mm	J ₂ mm	K ₁ mm	K ₂ mm	L mm
1000	115	150	78	246	186	350	75	230	50	4	215	34	17	82	44	20	14	21	48	31	84
2000	115	150	78	246	186	350	75	230	50	6	215	35	18	82	44	20	14	21	50	32	94
3000	180	225	80	320	232	455	80	320	70	8	255	35	21	120	75	22	30	34	60	40	122
5000	180	225	90	310	242	445	90	310	70	10	255	35	21	116	75	28	30	34	60	42	129
10000	175	220	90	320	268	480	90	320	70	14	275	35	20	110	66	38	34	35	60	40	146

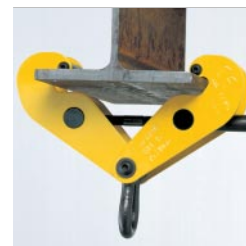
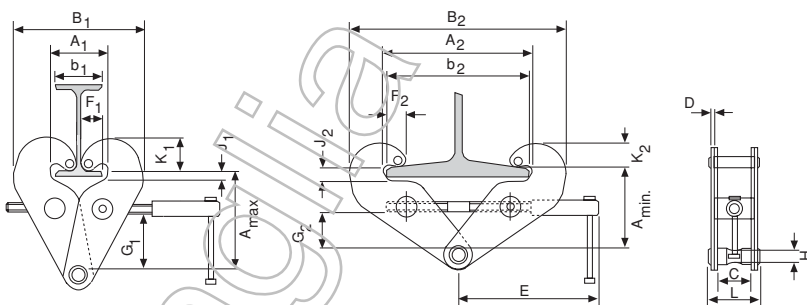

Clamp with shackle



Special design