

# BLOCKING SPRING

RESSORT DE MAINTIEN  
HALTEFEDER  
RESORTE DE FIJACIÓN



## MORE ERGONOMIC

- Allows the shackle to be maintained in its position
- No hindrance to the rotation of the ring during lifting process
- Available on models DSR / DSS / DSP / DSH / TSR

## PLUS ERGONOMIQUE

- Permet de maintenir la manille dans sa position
- Aucune entrave à la rotation de l'anneau lors du levage
- Disponible pour les modèles DSR / DSS / DSP / DSH / TSR

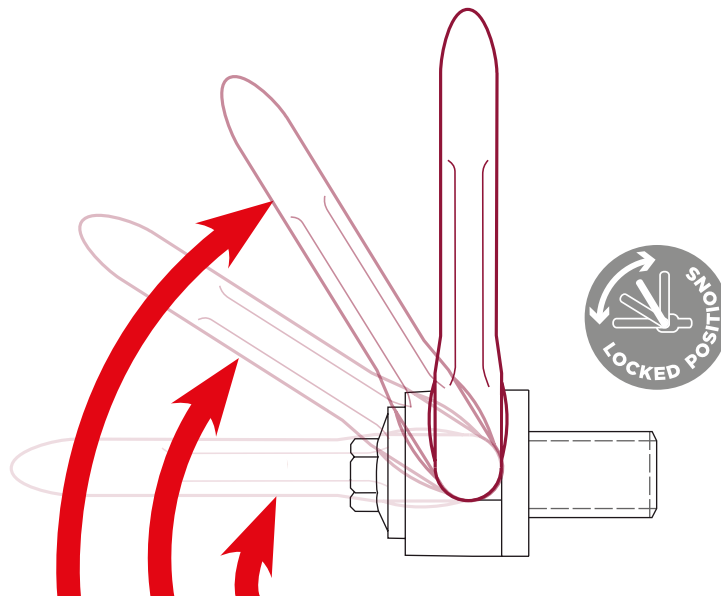

## ERGONOMISCHER

- Schäkel kann in seiner Position gehalten werden
- Kein Hindernis bei der Rotation der Ringschraube beim Heben
- Verfügbar für die Modelle DSR / DSS / DSP / DSH / TSR

## MÁS ERGONÓMICO

- Permite mantener el anillo en su posición
- Ningún obstáculo traba a la rotación del cáncamo durante la elevación
- Disponible para todos los modelos DSR / DSS / DSP / DSH / TSR



01767 312125



sales@angliahandling.co.uk



www.angliahandling.co.uk

# CENTRING

CENTRAGE  
ZENTRIERUNG  
CENTRAJE



## MORE SAFETY

- Reinforcement of the weakest point at 90°
- Higher WLL at 90° angle
- Increases the shearing off diameter
- Available on models SEB / DSR / DSS / TSR / DSP / DSH

## SÉCURITÉ ACCRUE

- Renforcement du point faible à 90°
- CMU améliorée avec angle à 90°
- Augmente le diamètre de cisaillement
- Disponible pour modèles SEB / DSR / DSS / TSR / DSP / DSH

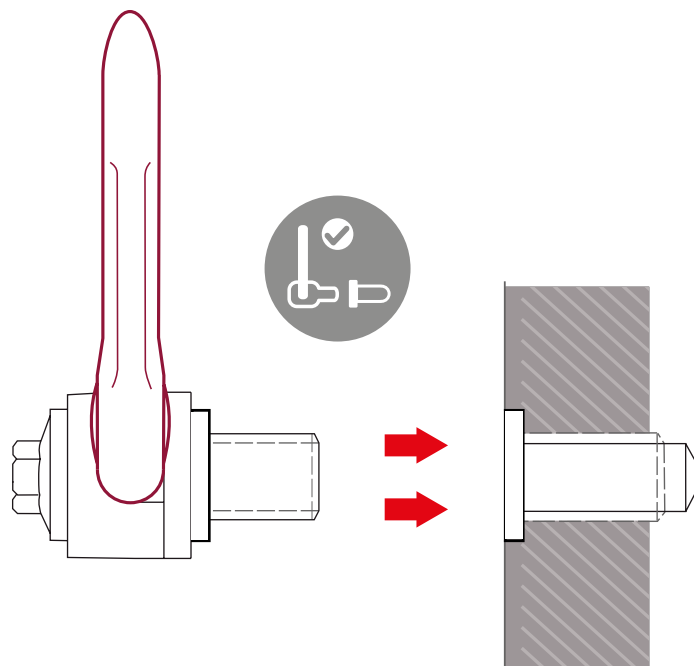

## NOCH MEHR SICHEREIT

- Verstärkung des schwächsten Punkt bei 90°-Hebung
- Höhere Tragfähigkeit bei 90°-Hebung
- Vergrößert den Abscherdurchmesser
- Verfügbar für die Modelle SEB / DSR / DSS / TSR / DSP / DSH

## AÚN MÁS SEGURIDAD

- Fortalecimiento del punto débil (90°)
- CMU más elevadas
- Aumento del diámetro de cizalladura
- Disponible para los modelos SEB / DSR / DSS / TSR / DSP / DSH



01767 312125



sales@angliahandling.co.uk



www.angliahandling.co.uk

# CENTRING DETAILS

## DÉTAILS DE CENTRAGE DETAILS DER ZENTRIERUNG EL CENTRAJE EN DETALLES

METRIC / UNC THREADS

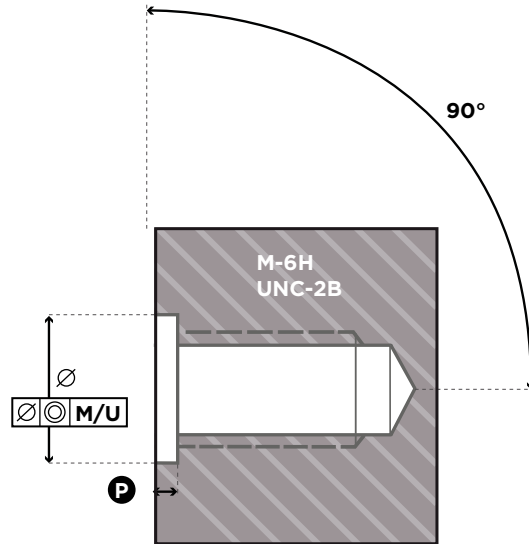

Metric	Ø (mm)	P (mm)
M 5	16 <sup>+0,25</sup> / <sub>0</sub>	3 <sup>+1</sup> / <sub>+0,5</sub>
M 6	16 <sup>+0,25</sup> / <sub>0</sub>	3 <sup>+1</sup> / <sub>+0,5</sub>
M 8	16 <sup>+0,25</sup> / <sub>0</sub>	3 <sup>+1</sup> / <sub>+0,5</sub>
M 10	20 <sup>+0,25</sup> / <sub>0</sub>	3 <sup>+1</sup> / <sub>+0,5</sub>
M 12	20 <sup>+0,25</sup> / <sub>0</sub>	3 <sup>+1</sup> / <sub>+0,5</sub>
M 14	20 <sup>+0,25</sup> / <sub>0</sub>	3 <sup>+1</sup> / <sub>+0,5</sub>
M 16	20 <sup>+0,25</sup> / <sub>0</sub>	3 <sup>+1</sup> / <sub>+0,5</sub>
M 18	30 <sup>+0,30</sup> / <sub>0</sub>	3 <sup>+1</sup> / <sub>+0,5</sub>
M 20	30 <sup>+0,30</sup> / <sub>0</sub>	3 <sup>+1</sup> / <sub>+0,5</sub>
M 22	30 <sup>+0,30</sup> / <sub>0</sub>	4 <sup>+1</sup> / <sub>+0,5</sub>
M 24	30 <sup>+0,30</sup> / <sub>0</sub>	4 <sup>+1</sup> / <sub>+0,5</sub>
M 27	36 <sup>+0,30</sup> / <sub>0</sub>	4 <sup>+1</sup> / <sub>+0,5</sub>
M 30	36 <sup>+0,30</sup> / <sub>0</sub>	4 <sup>+1</sup> / <sub>+0,5</sub>
M 33	48 <sup>+0,50</sup> / <sub>+0,10</sub>	6 <sup>+1</sup> / <sub>+0,5</sub>
M 36	48 <sup>+0,50</sup> / <sub>+0,10</sub>	6 <sup>+1</sup> / <sub>+0,5</sub>
M 39	48 <sup>+0,50</sup> / <sub>+0,10</sub>	6 <sup>+1</sup> / <sub>+0,5</sub>
M 42	48 <sup>+0,50</sup> / <sub>+0,10</sub>	6 <sup>+1</sup> / <sub>+0,5</sub>
M 45	48 <sup>+0,50</sup> / <sub>+0,10</sub>	6 <sup>+1</sup> / <sub>+0,5</sub>
M 48	64 <sup>+0,60</sup> / <sub>+0,10</sub>	8 <sup>+1</sup> / <sub>+0,5</sub>
M 52	64 <sup>+0,60</sup> / <sub>+0,10</sub>	8 <sup>+1</sup> / <sub>+0,5</sub>
M 56	64 <sup>+0,60</sup> / <sub>+0,10</sub>	8 <sup>+1</sup> / <sub>+0,5</sub>
M 64	74 <sup>+0,60</sup> / <sub>+0,10</sub>	10 <sup>+1</sup> / <sub>+0,5</sub>

UNC	Ø (mm)	P (mm)
1/4"	16 <sup>+0,25</sup> / <sub>0</sub>	3 <sup>+1</sup> / <sub>+0,5</sub>
5/16"	20 <sup>+0,25</sup> / <sub>0</sub>	3 <sup>+1</sup> / <sub>+0,5</sub>
3/8"	20 <sup>+0,25</sup> / <sub>0</sub>	3 <sup>+1</sup> / <sub>+0,5</sub>
1/2"	20 <sup>+0,25</sup> / <sub>0</sub>	3 <sup>+1</sup> / <sub>+0,5</sub>
5/8"	20 <sup>+0,25</sup> / <sub>0</sub>	3 <sup>+1</sup> / <sub>+0,5</sub>
3/4"	30 <sup>+0,30</sup> / <sub>0</sub>	3 <sup>+1</sup> / <sub>+0,5</sub>
7/8"	30 <sup>+0,30</sup> / <sub>0</sub>	4 <sup>+1</sup> / <sub>+0,5</sub>
1"	30 <sup>+0,30</sup> / <sub>0</sub>	4 <sup>+1</sup> / <sub>+0,5</sub>
1" 1/4	36 <sup>+0,30</sup> / <sub>0</sub>	4 <sup>+1</sup> / <sub>+0,5</sub>
1" 3/8	48 <sup>+0,50</sup> / <sub>+0,10</sub>	6 <sup>+1</sup> / <sub>+0,5</sub>
1" 1/2	48 <sup>+0,50</sup> / <sub>+0,10</sub>	6 <sup>+1</sup> / <sub>+0,5</sub>
2"	64 <sup>+0,60</sup> / <sub>+0,10</sub>	8 <sup>+1</sup> / <sub>+0,5</sub>
2" 1/2	74 <sup>+0,60</sup> / <sub>+0,10</sub>	10 <sup>+1</sup> / <sub>+0,5</sub>

1	DSR in stock / DSR en stock / DSR auf Lager / DSR en stock
1	DSS in stock / DSS en stock / DSS auf Lager / DSS en stock
✓	On request / Sur demande / Auf Anfrage / Bajo solicitud



# RFID

## RADIO FREQUENCY IDENTIFICATION



### OPTIMUM IDENTIFICATION AND TRACEABILITY

- Easy integration into all CODIPRO lifting rings
- Quick and efficient data reading, tracking and management
- Cost-savings and shorter control time
- Process reliability

### IDENTIFICATION ET TRAÇABILITÉ OPTIMALES

- Intégration aisée dans tous les anneaux de levage CODIPRO
- Lecture, suivi et gestion des informations efficaces et rapides
- Réduction des coûts et de la durée des contrôles
- Fiabilité du process

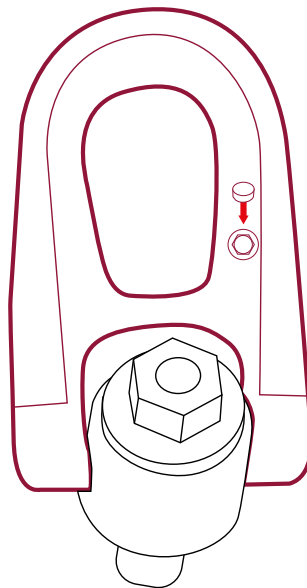

### OPTIMALE KENNZEICHNUNG UND RÜCKVERFOLGBARKEIT

- Einfache Integration in alle Wirbelringschrauben von CODIPRO
- Schnelle und effiziente Auslesung, Rückverfolgbarkeit und Verwaltung der Informationen
- Zeit- und Kostenersparnis bei UVV-Prüfungen
- Zuverlässige und fehlerfreie Datenspeicherung

### OPTIMIZACIÓN DE LA TRAZABILIDAD Y DE LA IDENTIFICACIÓN

- Fácil de integrar en los cáncamos de izaje CODIPRO
- Lectura, control y gestión de las informaciones rápidos y eficientes
- Reducción de los costes y del tiempo de revisión
- Fiabilidad del proceso



01767 312125



sales@angliahandling.co.uk



www.angliahandling.co.uk

# TORQUE KEY

EMBOU DE SERRAGE  
DREHMOMENTSCHLÜSSEL  
LLAVE DE FIJACIÓN

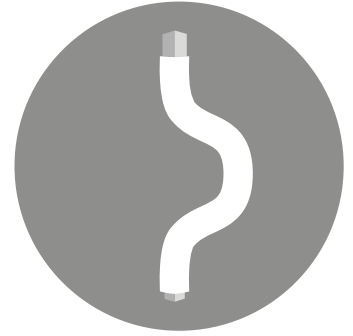

## FOR SEB MODELS M8 TO M24

- Easy tightening
- Allows to apply the recommended torque value
- Adapted for torque spanners
- Corrosion protection
- 3 sizes available

## POUR MODÈLES SEB M8 À M24

- Facilité de serrage
- Permet d'appliquer le couple de serrage recommandé
- Adapté pour les clés dynamométriques
- Protection contre la corrosion
- 3 tailles disponibles

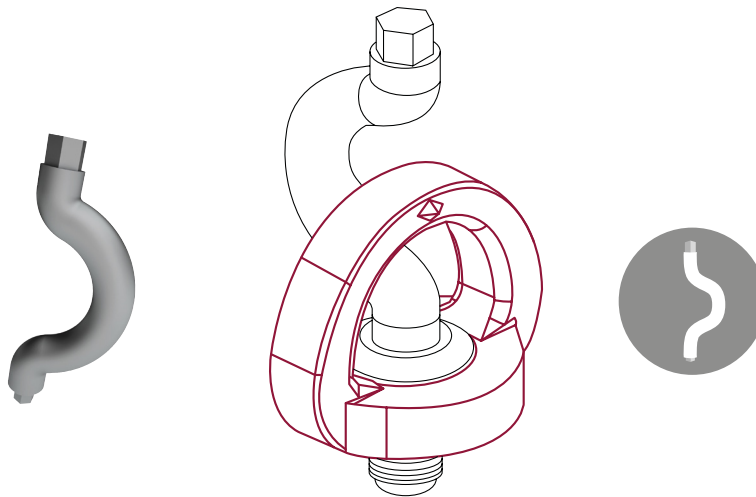

## FÜR SEB MODELLE M8 BIS M24

- Leichteres Einschrauben
- Erlaubt das empfohlene Drehmoment anzuwenden
- Für Drehmomentschlüssel geeignet
- Korrosionsschutz
- 3 verfügbare Größen

## PARA LOS MODELOS DEL SEB M8 AL M24

- Facilidad de apriete
- Permite aplicar par de apriete recomendado
- Adaptado para las llaves dinamométricas
- Protección contra la corrosión
- Disponible en 3 tallas

	SEB M 8 UP	SEB M 10 UP	SEB M 12 UP	SEB M 16 UP	SEB M 20 UP	SEB M 24 UP
key SEB - 1	X	X	X			
key SEB - 2				X	X	
key SEB - 3						X



01767 312125



sales@angliahandling.co.uk



www.angliahandling.co.uk

# LASHING

ARRIMAGE  
ZURRPUNKTE  
ESTIBA

  
**LASHING**

## CERTIFIED FOR LASHING

- Double use: lashing + lifting
- Double marking LC & WLL
- Slight extra cost
- Available on the whole range

## HOMOLOGUÉ POUR ARRIMAGE

- Double utilisation: arrimage + levage
- Double gravure LC & CMU
- Faible surcoût
- Disponible sur toute la gamme

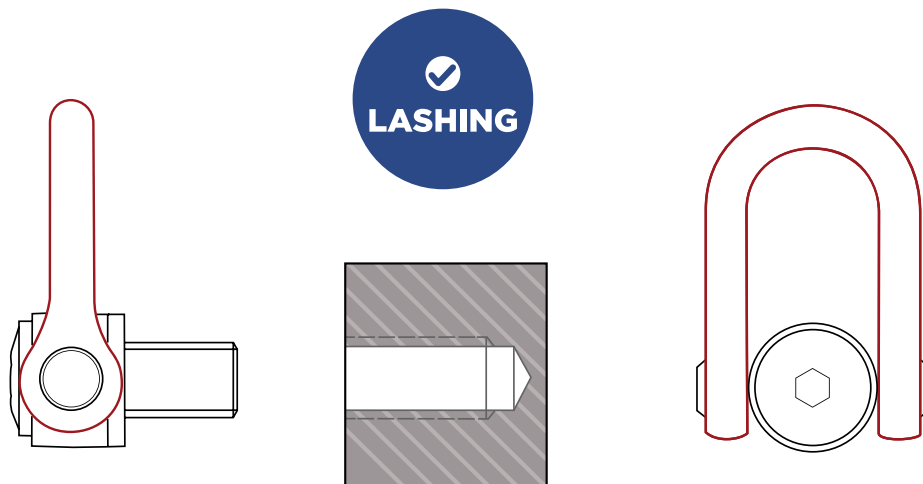

## ZERTIFIZIERT ALS ZURRPUNKT

- Doppelte Anwendungsmöglichkeit:  
Ladungssicherungs- und Hebemittel
- Zweifache Gravur LC & WLL
- Geringe Mehrkosten
- Verfügbar für die komplette Produktpalette

## HOMOLOGADOS PARA ESTIBAR

- Doble utilización: estiba + elevación
- Doble grabado LC & CMU
- Coste adicional mínimo
- Disponible para toda la gama



01767 312125



sales@angliahandling.co.uk



www.angliahandling.co.uk

# SCP

## SURFACE CONTACT PROTECT

# SCP

### ADHESIVE PROTECTIVE WASHER

- Insignificant lever arm thanks to its thickness of 250 µm
- No scratches or paint removal thanks to the proper bolt tightening
- Easy to replace in case of excessive wear
- Optional with the DSR lifting rings

### RONDELLE ADHÉSIVE DE PROTECTION

- Bras de levier négligeable par son épaisseur de 250 µm
- Evite les griffes ou l'enlèvement de peinture dû à la fixation par vissage de l'anneau
- Simple à remplacer en cas d'usure
- Optionnel pour les anneaux DSR

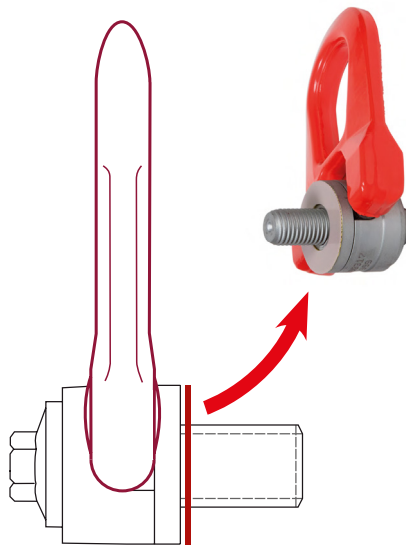

# SCP

### SELBSTKLEBENDE SCHUTZFOLIE

- Fast keine Verlängerung des Hebelarms durch ein Foliendicke von 250 µm
- Vermeidet Beschädigungen and der Last, die gehoben wird
- Leicht zu ersetzen
- Optional für DSR-Wirbelringschrauben

### ARANDELA ADHESIVA DE PROTECCIÓN

- Efecto palanca desdeñable por su espesor de 250 µm
- Elimina los riesgos de garras o de retirada de pintura debido a la fijación del cáncamo
- Simple a sustituir en caso de desgaste
- Opcional por los cáncamos DSR



01767 312125



sales@angliahandling.co.uk



www.angliahandling.co.uk