

530

Aluminium Crane



- Light weight aluminium construction
- Continuously adjustable width
- Adjustable length of supports
- Erection aid on request
- Foldable construction, light transportation and easy assembly

The perfect aluminium crane for the fast erection and dismantling. Ideal for site changes.

Beam and supports of the crane are manufactured of high quality aluminium profiles. This makes the construction very light and can be easily carried by two people.

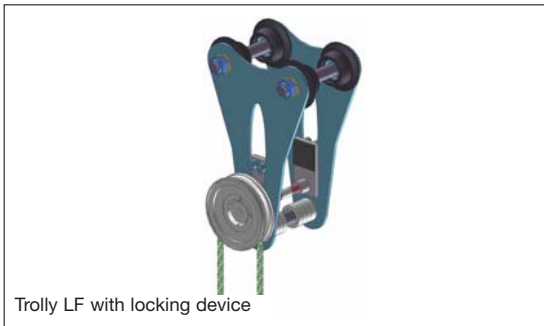

Due to link joints between beam and supports the crane is easily erected by one person: fold out the four supports, secure with bolts and adjust to the height required. In this case the erecting aid would prove to be useful, available as accessory.

As a standard delivery the distance between the supports can be continuously adjusted on both sides via two screw adjustments.

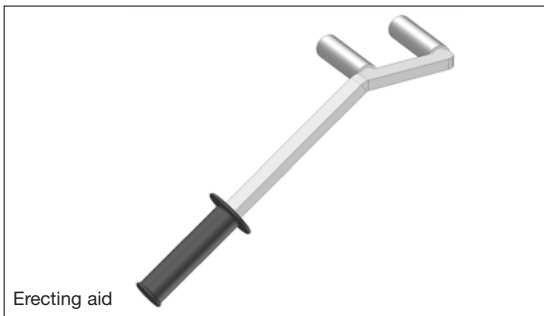

The length of the supports can be adjusted; a big advantage when operating on uneven ground.

The crane is equipped with a ball bearing trolley LK, easily moveable by pushing the load.

On request, the trolley is also available with a locking device: trolley LF. The trolley can be fitted with a manual hoist.

When the crane is not needed, it can be easily folded and stored, requiring very little space.

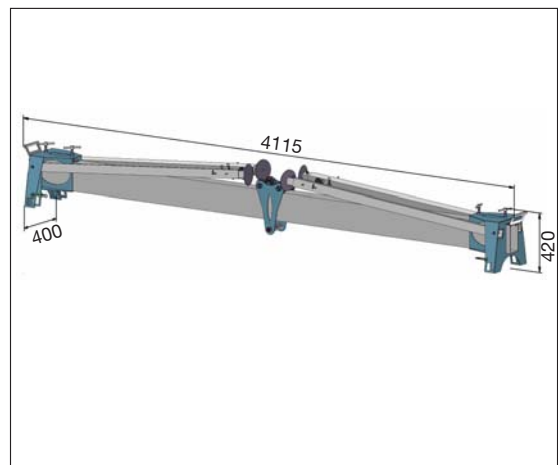
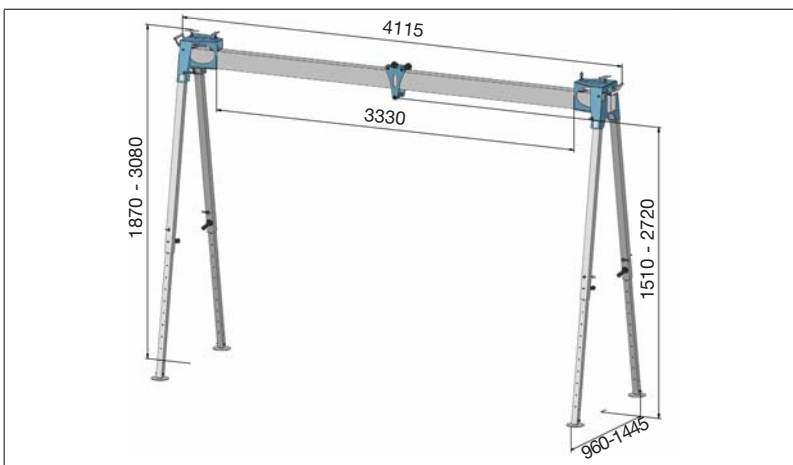

Order No.	Model	Safe Working Load	Weight
530 075	Aluminium crane AK 750 with trolley LK 750	750 kg	85 kg
722 031	Manuel chain hoist HZB 1,0, lifting height 3 m, construction height 383 mm	1.000 kg	13 kg
048 672	Locking device for trolley LF 750	750 kg	8 kg
530 150	Aluminium crane AK 1500 with trolley LK 1500	1.500 kg	105 kg
722 041	Manuel chain hoist HZB 2,0, lifting height 3 m, construction height 485 mm	2.000 kg	18 kg
048 671	Locking device for trolley LF 1500	1.500 kg	9 kg
048 641	Erection aid (2 pieces)		3 kg