

WH-GT Corrosion Protected Geared Trolley

The Anglia Handling WH-GT Corrosion Protected Geared Trolleys meet and exceed the requirements of the following international standards: British Standard BS EN 13157:2004 + A1:2009.

This high quality trolley range is precision engineered in W.L.L. capacities from 500 kg to 5 tonnes.

Enabling exact positioning or easy traversing of large loads incorporating Manual hoists, the Anglia Handling series geared trolley can be supplied to suit various track widths with beam range 1 and the extended beam range 2.

It has been designed so that the bottom of the hand chain loop is located approximately 500mm from ground level.

The runners (trolley wheels) are precision machined and they rotate on maintenance sealed ball bearings.

All Anglia Handling geared trolleys are fitted with anti-jump bars rubber end stops as standard.



Specifications

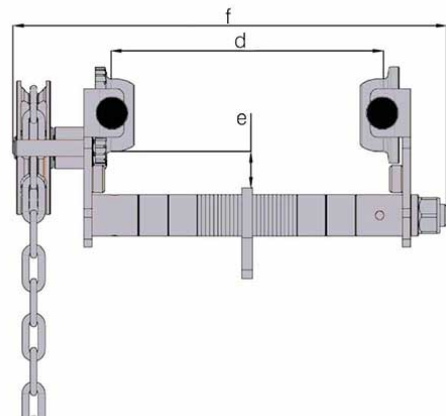
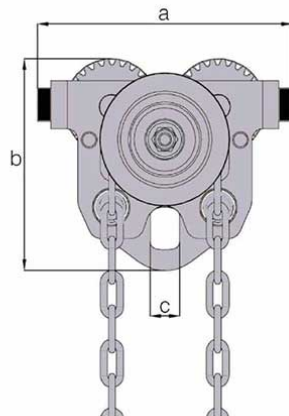

| Part Code | WLL t | Min.radius of Curve m | a mm | b mm | c mm | e mm |
|------------|----------|--------------------------|---------|---------|---------|---------|
| 055.050.CP | 0.50 | 0.8 | 190 | 154 | 22 | 27 |
| 055.100.CP | 1.00 | 0.9 | 206 | 180 | 30 | 26 |
| 055.200.CP | 2.00 | 1.0 | 246 | 210 | 37 | 26 |
| 055.320.CP | 3.20 | 1.2 | 300 | 249 | 42 | 28 |
| 055.500.CP | 5.00 | 1.3 | 336 | 277 | 50 | 37 |

Standard Range 1

| WLL t | I Beam Width mm | d Max. width mm | f Max. mm | Mass kg |
|----------|--------------------|--------------------|--------------|------------|
| 0.50 | 50-203 | 203 | 323 | 9.60 |
| 1.00 | 64-203 | 203 | 332 | 12.30 |
| 2.00 | 88-203 | 203 | 341 | 17.20 |
| 3.20 | 100-203 | 203 | 359 | 28.40 |
| 5.00 | 114-203 | 203 | 366 | 40.10 |

Extended Range 2

| WLL t | I Beam Width mm | d Max. width mm | f Max. mm | Mass kg |
|----------|--------------------|--------------------|--------------|------------|
| 0.50 | - | - | - | - |
| 1.00 | 64-305 | 305 | 434 | 13.70 |
| 2.00 | 88-305 | 305 | 443 | 19.00 |
| 3.20 | 100-305 | 305 | 461 | 31.20 |
| 5.00 | 114-305 | 305 | 468 | 44.20 |

