

Manual trolleys HTP/G



Push type model HTP

Capacities 500 - 5.000 kg

Geared type model HTG

Capacities 500 - 20.000 kg

The trolley enables the exact positioning or easy traversing of large loads with either manual or powered hoisting equipment. It has excellent rolling features due to machined steel wheels mounted on prelubricated, encapsulated ball bearings.

Adjustable to fit a wide range of beam widths and profiles (e.g. INP, IPE and IPB). The trolley wheels are designed for a max. beam profile incline of 14%. Adjustments are made by rotating the clevis load bar which also ensures the centred positioning of the hoist in the clevis - no creeping to the left or the right. Anti-tilt and wheel fracture support devices according to DIN 15018 and the machinery directives are standard.

Optional

- Buffers can be fitted.
- Locking device to secure the trolley in position on the beam (park position e.g. on ships).
- Rust and acid resistant hand chains.

Technical Data

Model	Capacity kg	Size	Beam flange width b mm	Max. flange thickness t mm	Min. radius curve m	Effort at WLL daN	Net weight in kg			
							HTP	HTG*	with locking device HTP	with locking device HTG*
HTP/G	500	A	50 - 220	25	0,90	3	8,0	9,7	14,5	16,2
		B	160 - 300	40			10,6	12,6	17,1	19,1
HTP/G	1000	A	50 - 220	25	0,90	6	9,0	11,2	17,0	19,2
		B	160 - 300	40			12,0	14,1	20,0	22,1
HTP/G	2000	A	66 - 220	25	1,15	7	16,0	18,0	24,0	26,0
		B	160 - 300	40			19,3	21,3	27,3	29,3
HTP/G	3000	A	74 - 220	25	1,40	7	32,0	35,4	41,2	44,6
		B	160 - 300	40			35,8	39,2	45,0	48,4
HTP/G	5000	A	90 - 220	25	1,80	9	48,0	51,8	58,5	62,3
		B	180 - 300	40			52,2	56,0	62,7	66,5
HTG	10000	B	125 - 310	40	1,80	14	-	104,0	-	-
HTG	20000	B	125 - 310	40	5,00	29	-	230,0	-	-

*without hand chain

Dimensions HTP/G in mm

Dimension	HTP/G 500		HTP/G 1000		HTP/G 2000		HTP/G 3000		HTP/G 5000		HTG 10000	HTG 20000
	A	B	A	B	A	B	A	B	A	B	B	B
A	77,0	92,0	82,5	97,5	98,5	113,5	114,0	129,0	132,5	147,5	276,0	270,0
B	-	-	-	-	-	-	-	-	-	-	52	70
D	16	16	17	17	22	22	26	26	33	33	30	35
D ₁	25	25	30	30	40	40	48	48	60	60	80	110
D ₂	30	30	35	35	47	47	58	58	70	70	114	155
F (HTG)	91,5	91,5	91,5	91,5	90,5	90,5	107,5	107,5	149,5	149,5	113,0	113,0
F ₁	46,0	46,0	46,0	46,0	46,0	46,0	46,0	46,0	45,5	45,5	-	-
H ₁	30,5	45,5	30,5	45,5	30,5	45,5	30,0	45,0	30,0	45,0	45,0	45,0
I (HTP)	71,5	71,5	71,5	71,5	95,5	95,5	131,0	131,0	142,5	142,5	-	-
I (HTG)	76,5	76,5	76,5	76,5	98,0	98,0	132,5	132,5	148,5	148,5	170,0	170,0
L	260	260	260	260	310	310	390	390	450	450	430	870
L ₁	130	130	130	130	150	150	180	180	209	209	200	200
L ₂	-	-	-	-	-	-	-	-	-	-	-	115
O	60	60	60	60	80	80	112	112	125	125	150	150
P (HTG)	110	110	110	110	110	110	110	110	110	110	163	163
P ₁	168	168	168	168	168	168	168	168	168	168	-	-
P ₂	146,0	146,0	150,0	150,0	155,0	155,0	160,0	160,0	167,5	167,5	-	-
T	146,0	187,0	150,0	187,0	155,0	189,5	160,0	191,5	167,5	191,5	270,0	270,0

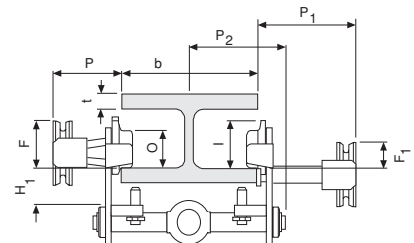
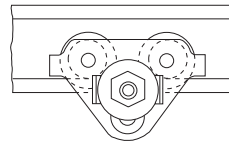
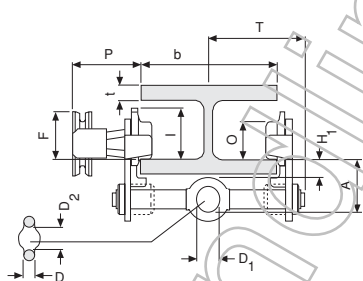
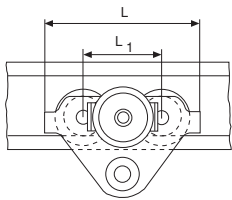

Model HTP/G

500 - 5.000 kg

Model HTP/G

with locking device

500 - 5.000 kg

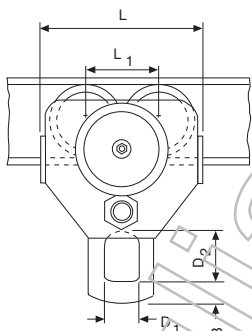

Model HTG

10.000 kg

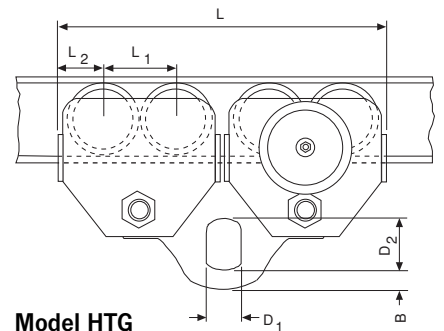
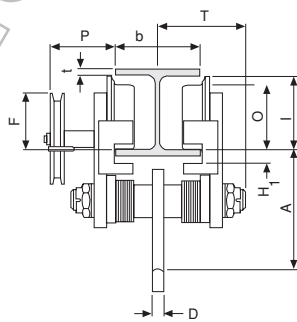

Model HTG

20.000 kg