

Overhead Travelling Cranes

Overhead travelling cranes are the answer to many lifting and movement problems in factories, warehouses and stockyards. Cranes may be overslung or underslung with single or double girders to suit the building and application involved. Operation can be manual or power driven in the long travel, cross travel and lifting movements or a combination of the two.

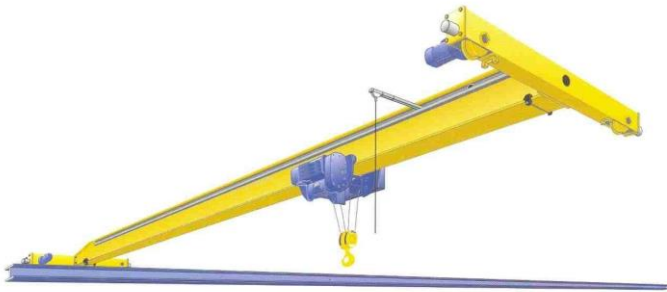

Single Girder overslung (top running) travelling crane.

Maximum Capacity: 10 tonne
Maximum Span: 36 metres

Hoist Options: Chain or Wire Rope

Control Options: Manual Hand Chain
Mobile Pendant
Remote Control



Single Girder underslung (bottom running) travelling crane.

Maximum Capacity: 8 tonne
Maximum Span: 25 metres

Hoist Options: Chain or Wire Rope

Control Options: Manual Hand Chain
Mobile Pendant
Remote Control



Double Girder overslung (top running) travelling crane.

Maximum Capacity: 80 tonne
Maximum Span: 36 metres

Hoist Options: Wire Rope

Control Options: Mobile Pendant
Remote Control

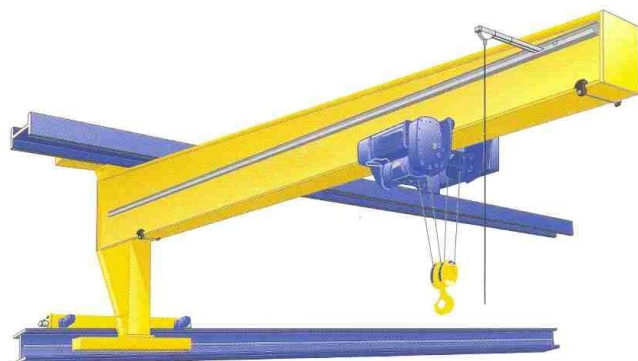

Single Girder wall travelling crane.

Maximum Capacity: 5 tonne
Maximum Span: 10 metres

Hoist Options: Chain or Wire Rope

Control Options: Manual
Mobile Pendant
Remote Control