

## *Lifting / Spreader Beams*

Designed and manufactured to suit your individual application to lift large or awkward loads with a high degree of safety.

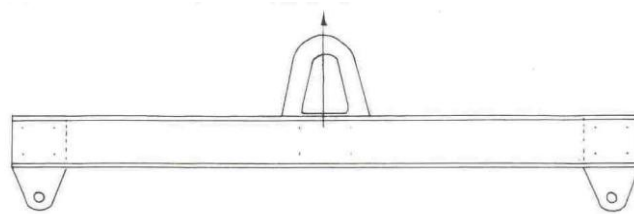

Two point pick up with a central lifting eye

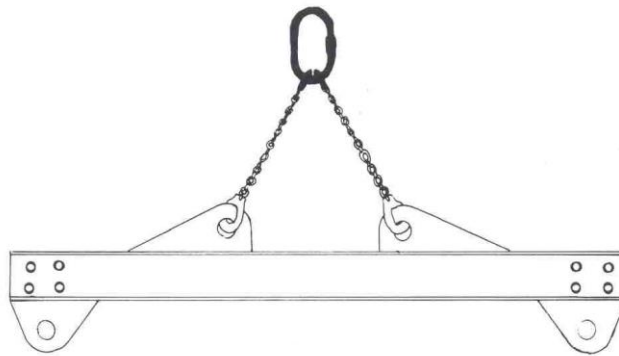

Two point pick up with a 2-leg sling suspension inset from each end



Two point pick up with a 2-leg sling suspension at each end

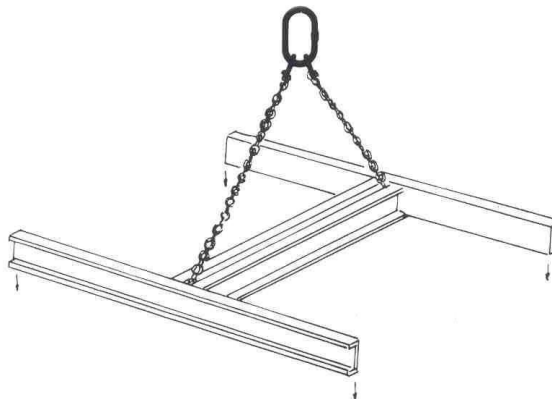

'H' frame four point pick up with a 2-leg suspension

These illustrations show simple examples of a few beam types only. Please consult our technical sales staff regarding your specific application.