

## VacuEasylift Vacuum Lifting Hoists

The VacuEasylift is a manually operated powered vacuum lifting device that handles almost any type of load. The extremely smooth and quick operation is accomplished by using the same handle to lift, lower and release the load and by using the same vacuum to hold and lift the load. By supplying the VacuEasylift with a vast variety of suction feet it can be used to lift anything from a cardboard box to a television.

### Typical Applications

- Boxes
- Reels
- Wood
- Steel
- Windows
- Sacks
- Cheese
- Paper
- Pallets
- Televisions
- Plastic
- Stone

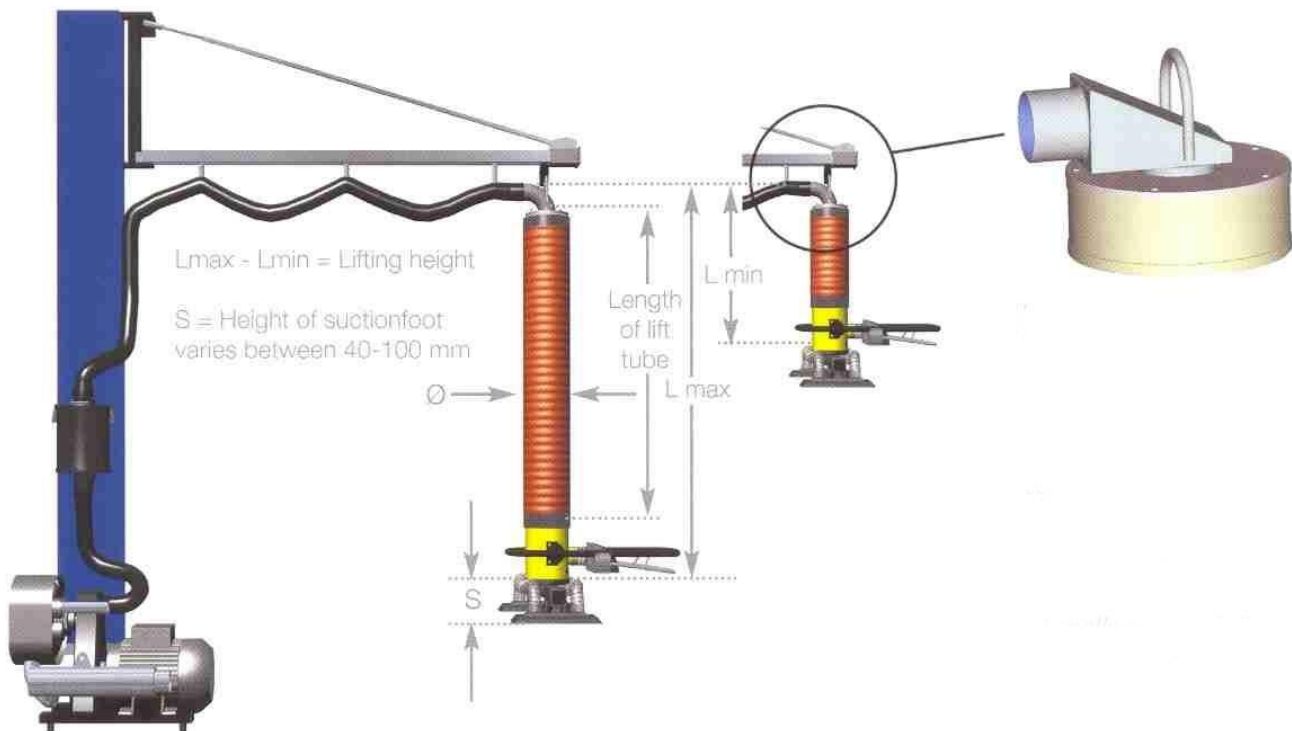

### Specifications

Model	VM80	VM100/120/140	VM160/180	VM200/230	VM250	VM2160/2180	VM300
Lifting cap. kg	20	30/40/50	60/80	100/120	180	120/160	270
Length of lift tube	2000	2500   4000	2500   4000	2500   4000	2500	2500   4000	2500
Ø mm	80	100/120/140	160/180	200/230	250	2x160/2x180	300
L max.	2240	2670   4170	2690   4190	2690   4190	2690	2630   4130	2690
L min.	740	870   1570	890   1590	990   1790	1190	830   1530	1190
Lifting height	1500	1800   2600	1800   2600	1700   2400	1500	1800   2600	1500
Extended, flexible handle	N/A	Flexed extensions up to 800+800 mm standard	Flexed extensions up to 800+800 mm standard	Flexed extensions up to 800+800 mm standard	N/A	Available on request	N/A

**Optional Extras** include a bottom swivel, quick release couplings, a 90 degree angle adaptor, white non marking suction pads, stainless steel fittings etc.